

# Exterior Wall Sconce

Part Number

**A6040-BK**

Project \_\_\_\_\_

Date \_\_\_\_\_

Type \_\_\_\_\_

Location \_\_\_\_\_

## Product Specifications

Description	1-Light industrial farmhouse wall sconce Exterior use Ambient lighting
Finish	Black
Construction	Durable die cast aluminum
Dimensions	12"Width x 11"Height x 14"Extension
Lamps	1 x LED (E26 Medium Base) not included
Certifications	cETLus Listed   CSA Certified Suitable for wet locations
Notes	120V   60Hz Vertical wall mount only (hardware included) Open bottom for easy lamp access



# Exterior Wall Sconce

Part Number

**A6040-BK**

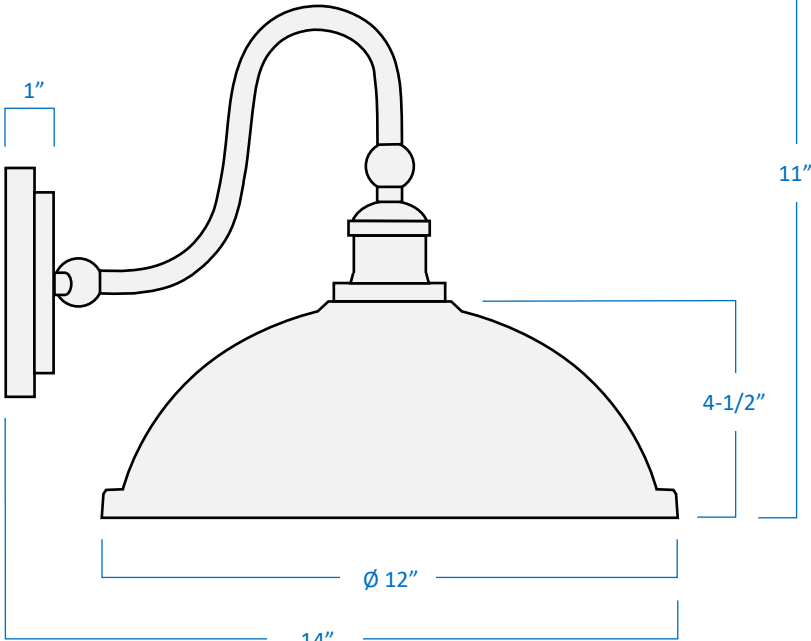

Side View

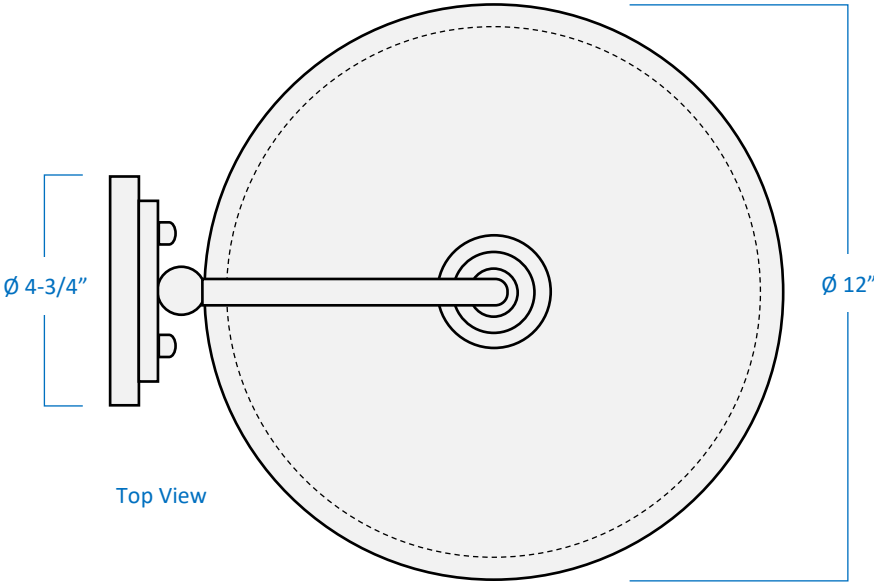

Top View

Front View of Back Plate

