

# 1-Light Exterior Hanging Lantern

Part Number

**A0214H-BK**

Project \_\_\_\_\_

Date \_\_\_\_\_

Type \_\_\_\_\_

Location \_\_\_\_\_

## Product Specifications

Description	1-Light contemporary hanging lantern Exterior use Ambient lighting
Finish	Black
Construction	Durable die cast aluminum Frosted glass
Dimensions	8-1/2" Width x 8-1/2" Length x 14" Height Includes 24" adjustable chain & canopy
Certifications	cETLus Listed Certified to CSA standards Suitable for wet locations
Lamp	1 x LED (E26 Medium Base) not included
Notes	<ul style="list-style-type: none"><li>▪ 120V   60Hz</li><li>▪ Ceiling mounting only</li><li>▪ Mounting hardware included</li></ul>

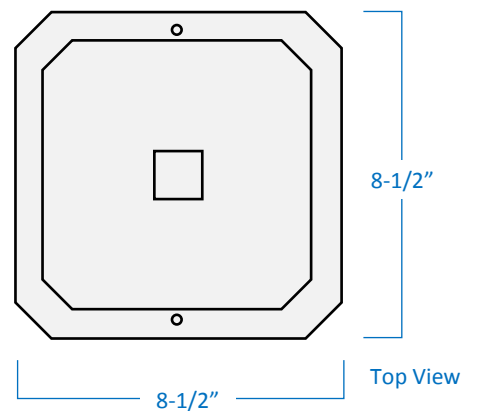
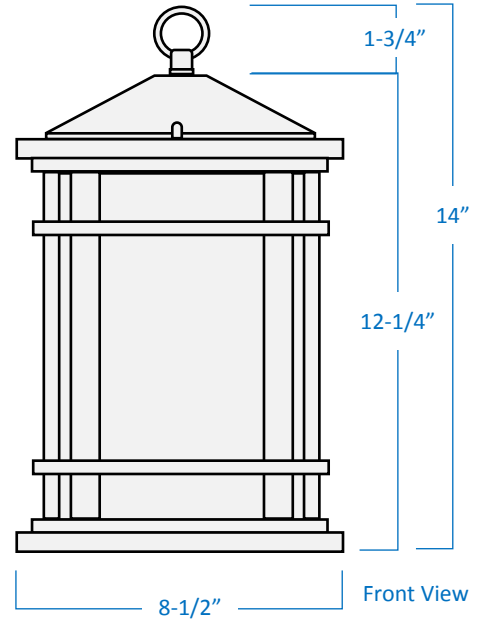

Head Office: 151 Aviva Park Drive, Woodbridge, ON L4L 9C1  
Ottawa Office: 200 Iber Road, Unit 5, Stittsville, ON K2S 0L5

Tel: 905-669-1230  
Tel: 613-836-1977

© SanRemoLighting.com  
Toll Free: 1-800-903-1115