

Exterior Hanging Lantern

Part Number

B0288H-BK

Project _____

Date _____

Type _____

Location _____

Product Specifications

Description	1-Light contemporary hanging lantern Exterior ambient lighting
Finish	Black
Construction	Durable die cast aluminum Clear seeded glass
Dimensions	9"Width x 9"Length x 12"Height Includes 24" adjustable chain & canopy
Lamp	1 x LED (E26 Medium Base) INCLUDED
Certifications	cETLus Listed CSA Certified Suitable for wet locations
Notes	120V 60Hz Ceiling mount only (hardware included)

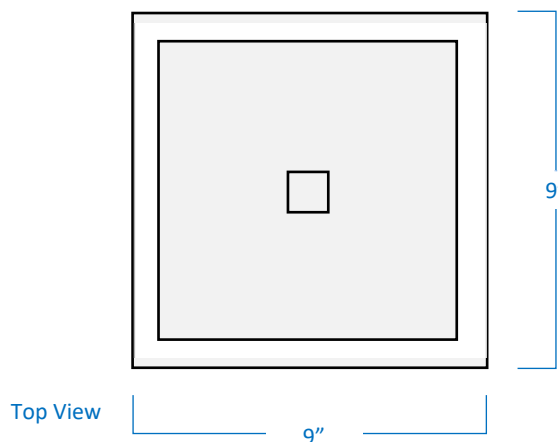
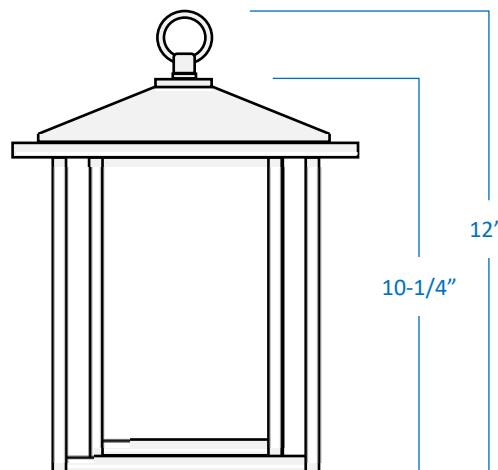

Head Office: 151 Aviva Park Drive, Woodbridge, ON L4L 9C1
Ottawa Office: 200 Iber Road, Unit 5, Stittsville, ON K2S 0L5

Tel: 905-669-1230
Tel: 613-836-1977

© SanRemoLighting.com
Toll Free: 1-800-903-1115