

Round "Marine" Light with Guard

Project _____

Date _____

Type _____

Location _____

Part Number **Finish**

A305012-BK Black

A305012-WH White

Product Specifications

Description	1-Light round marine light with guard Exterior use Ambient lighting
Construction	Die cast aluminum Frosted & ribbed glass
Dimensions	8" Diameter x 4" Extension
Lamps	1 x LED A19 (E26 Medium Base) not included
Certifications	cULus Listed CSA Certified Suitable for wet locations
Features	120V 60Hz Wall or ceiling mount (hardware included)

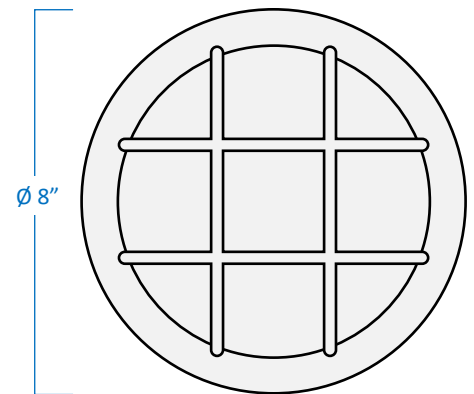
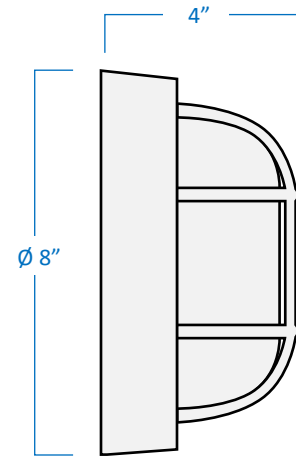

GTA Office: 151 Aviva Park Drive, Woodbridge
Ottawa Office: 200 Iber Road, Unit 5, Stittsville

Tel: 905-669-1230
Tel: 613-836-1977

www.sanremolighting.com
© All rights reserved