

Oval "Marine" Light with Guard

Part Number **Finish**
A305011-BK Black
A305011-WH White

Project _____
Date _____
Type _____
Location _____

Product Specifications

Description	Oval marine-style light with guard Exterior use - Ambient lighting
Construction	Die cast aluminum Frosted & ribbed glass
Dimensions	5"Width x 8-1/2"Length x 4"Extension
Lamps	1 x LED A19 (E26 Medium Base) not included
Certifications	cULus Listed CSA Certified Suitable for wet locations
Features	120V 60Hz Wall mount in horizontal or vertical position Ceiling mount (hardware included)

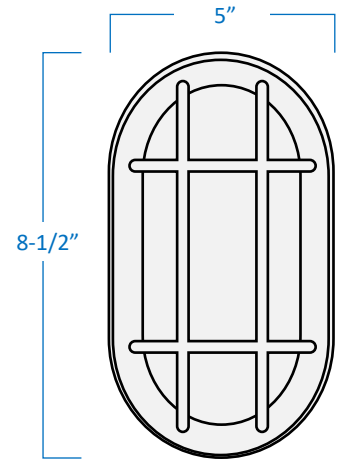
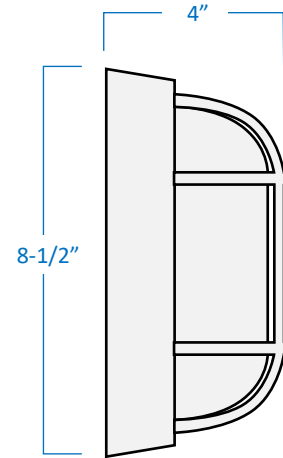

GTA Office: 151 Aviva Park Drive, Woodbridge
Ottawa Office: 200 Iber Road, Unit 5, Stittsville

Tel: 905-669-1230
Tel: 613-836-1977

www.sanremolighting.com
© All rights reserved