

3-Light Exterior Hanging Lantern

Part Number

A6023-BK

Project _____

Date _____

Type _____

Location _____

Product Specifications

Description	3-Light exterior traditional hanging lantern Ambient lighting
Finish	Black
Construction	Die cast aluminum Clear seeded glass
Dimensions	9-1/4" Width x 9-1/4" Length x 17-1/2" Height
Lamps	3 x LED B10 (E12 Candelabra Base) not included
Certifications	cETLus Listed CSA Certified Suitable for wet locations
Features	120V 60Hz Ceiling mount only (hardware Included) Includes 24" adjustable chain & canopy

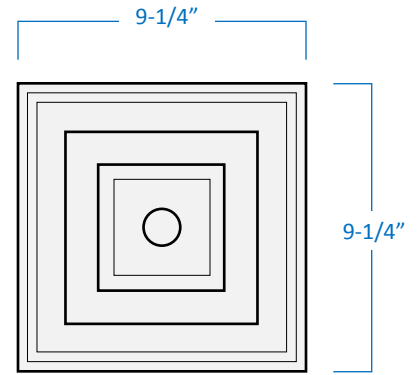

Top View

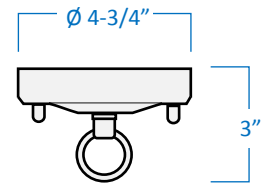

Canopy Side View

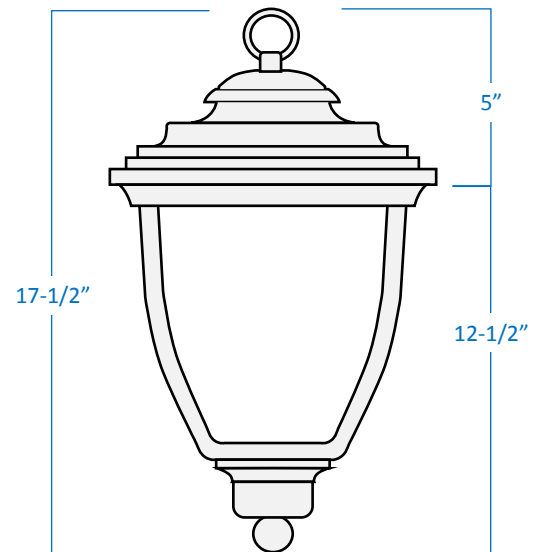

Side View



GTA Office: 151 Aviva Park Drive, Woodbridge
Ottawa Office: 200 Iber Road, Unit 5, Stittsville

Tel: 905-669-1230
Tel: 613-836-1977

www.sanremolighting.com
© All rights reserved