

3-Light Pendant

Project _____

Date _____

Type _____

Location _____

Part Number

Finish

A51053-BN

Brushed Nickel

A51053-CH

Chrome

Product Specifications

Description	Distinguished by its crisp, modern elements, the Rhythm Collection 3-Light Pendant sports an enhanced white glass shade and highly polished design to provide a sophisticated accent to any home décor. Perfect for the foyer, stairwells, and dining areas.
Shade	White glass
Dimensions	16" Diameter x 23" Height (Includes approx. 72" chain) Approx. 97" Max. Height with chain and canopy
Lamps	3 x LED A19 (E26 Medium Base) not Included
Certifications	cULus Listed CSA Certified
Features	120V 60Hz Ceiling mounting only (hardware included)

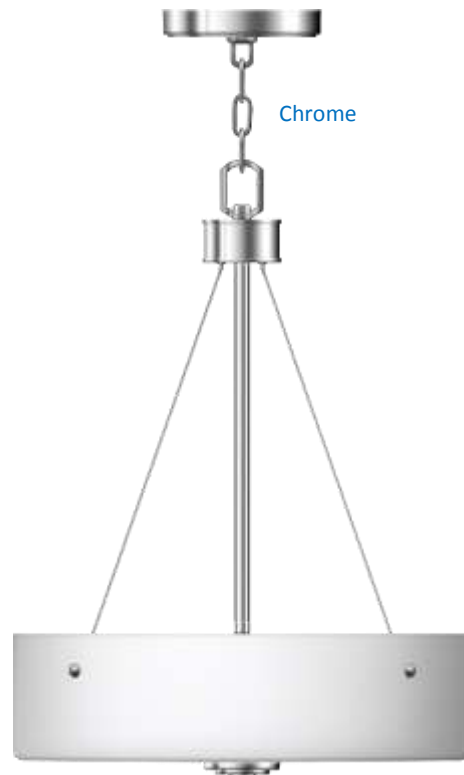

GTA Office: 151 Aviva Park Drive, Woodbridge
Ottawa Office: 200 Iber Road, Unit 5, Stittsville

Tel: 905-669-1230
Tel: 613-836-1977

www.sanremolighting.com
© All rights reserved

3-Light Pendant

Part Number

A51053-BN

A51053-CH

Finish

Brushed Nickel

Chrome

Project _____

Date _____

Type _____

Location _____

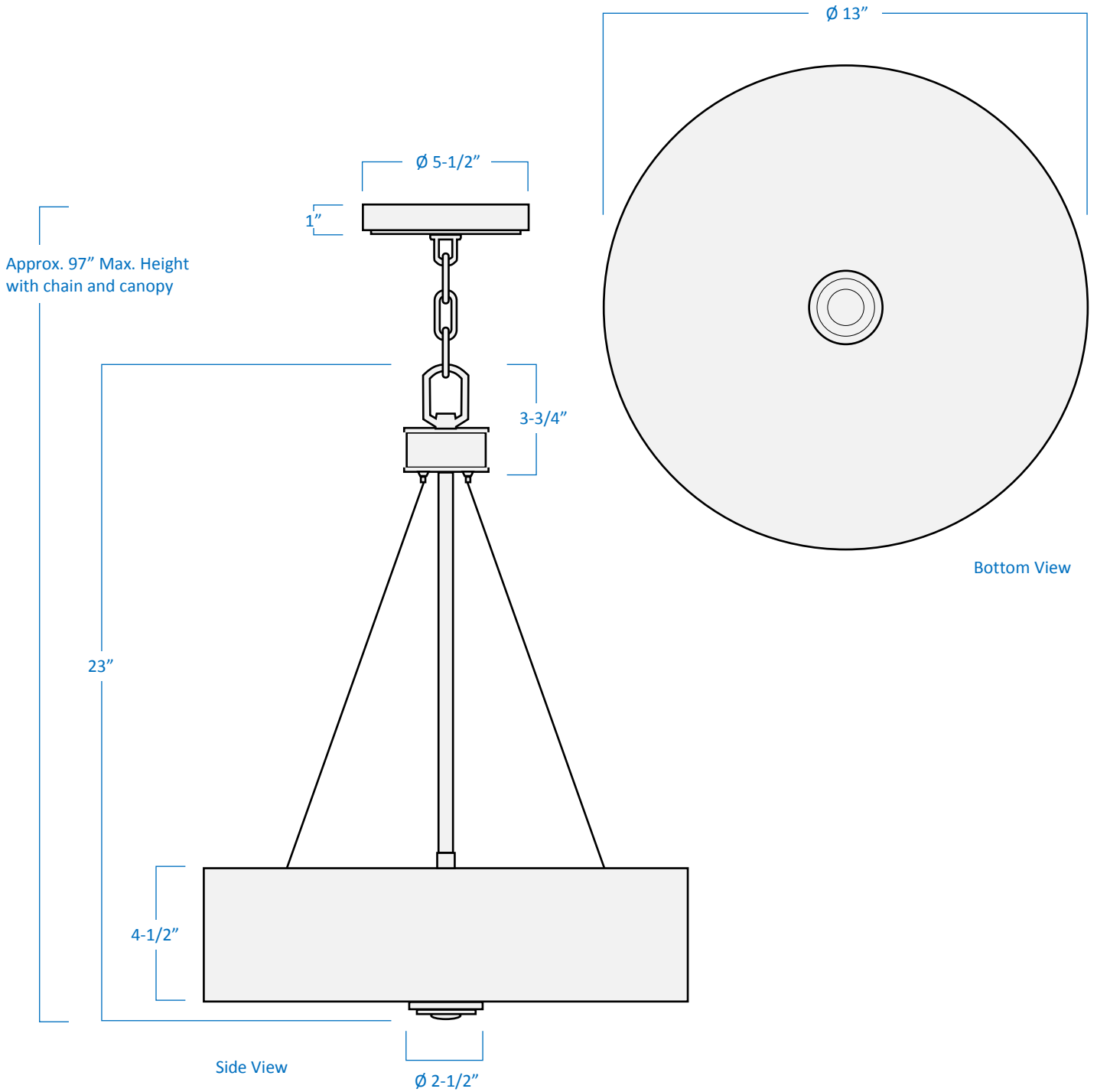

GTA Office: 151 Aviva Park Drive, Woodbridge
Ottawa Office: 200 Iber Road, Unit 5, Stittsville

Tel: 905-669-1230
Tel: 613-836-1977

www.sanremolighting.com
© All rights reserved