

# 1-Light Exterior Hanging Lantern

Part Number

**A4083-BK**

Project \_\_\_\_\_

Date \_\_\_\_\_

Type \_\_\_\_\_

Location \_\_\_\_\_

## Product Specifications

|                |  |
|----------------|--|
| Description    | 1-Light contemporary hanging lantern<br>Exterior use<br>Ambient lighting   |
| Finish         | Black  |
| Construction   | Durable die cast aluminum<br>Clear seeded glass  |
| Dimensions     | 9"Width x 9"Length x 14"Height<br>Includes 24" adjustable chain & canopy   |
| Certifications | cETLus Listed<br>Certified to CSA standards<br>Suitable for wet locations  |
| Lamp           | 1 x LED (E26 Medium Base) not included   |
| Notes          | <ul style="list-style-type: none"><li>▪ 120V   60Hz</li><li>▪ Ceiling mounting only</li><li>▪ Mounting hardware included</li></ul> |

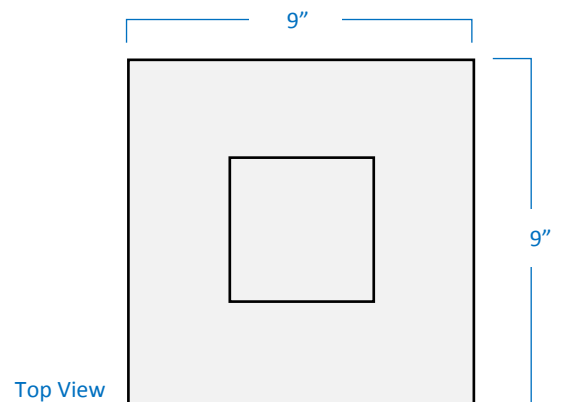
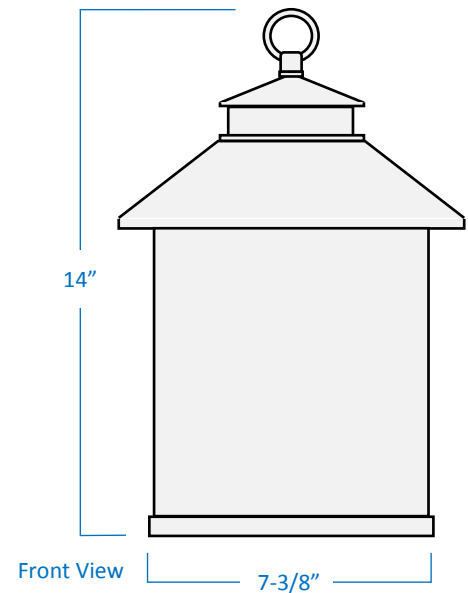

Head Office: 151 Aviva Park Drive, Woodbridge, ON L4L 9C1  
Ottawa Office: 200 Iber Road, Unit 5, Stittsville, ON K2S 0L5

Tel: 905-669-1230  
Tel: 613-836-1977

© SanRemoLighting.com  
Toll Free: 1-800-903-1115